

Table of Contents:

1. Product Description	2
2. General	2
3. Pre-Installation Checks	2
4. Equipment required for Installation	2
5. General Installation Notes	3
5.1 Determination of Pipe Arrangement	3
5.2 Vertical Pipe Arrangement	3
5.3 Horizontal Pipe Arrangement	3
5.4 Misalignment	4
5.5 Required undisturbed Pipe Run Lengths	5
6. Installation of the ITABAR Sensor	6
6.1 Installation of Type FTMD25	6
6.2 Installation of Type FTMD26	7
6.3 Insertion Procedure for FTMD	8
6.4 Retract Procedure for FTMD	8
7. Installation of the Attachments and the Δp -Transmitter	9
7.1 Attachments	9
7.2 Δp -Transmitter	9
8. Measurement Start-Up	9
9. Preventive Maintenance of the ITABAR Sensors	10
10. Trouble Shooting	10

INTRA-AUTOMATION GmbH
Meß- und Regelinstrumente
Otto- Hahn- Straße 20
D-41515 Grevenbroich / GERMANY

Tel.: (+49) 21 81/68761
Fax.: (+49) 21 81/64492
Telex: 8 517 226 INTA
E-MAIL: Intra-Automation @ T-Online.de

BA-E-041Rev.0/03.09.97

1. Product Description

When installed properly, the ITABAR sensor offers an array of advantages over other measurement systems with respect to its accuracy, pressure loss, and installation. The following guide line is designed to help you with the sensor installation and operation.

The ITABAR flow sensor is so constructed, that all cross sections have a min. diameter of 8 mm (Fig.1). So it's guarantee, that condensate with a max drop diameter of 6,5 mm can flow back from the condensate pots into the flow sensor. So it can continuous a change of condition of aggregation from liquid to steam. (Prandl,L. "Führer durch Strömungslehre").

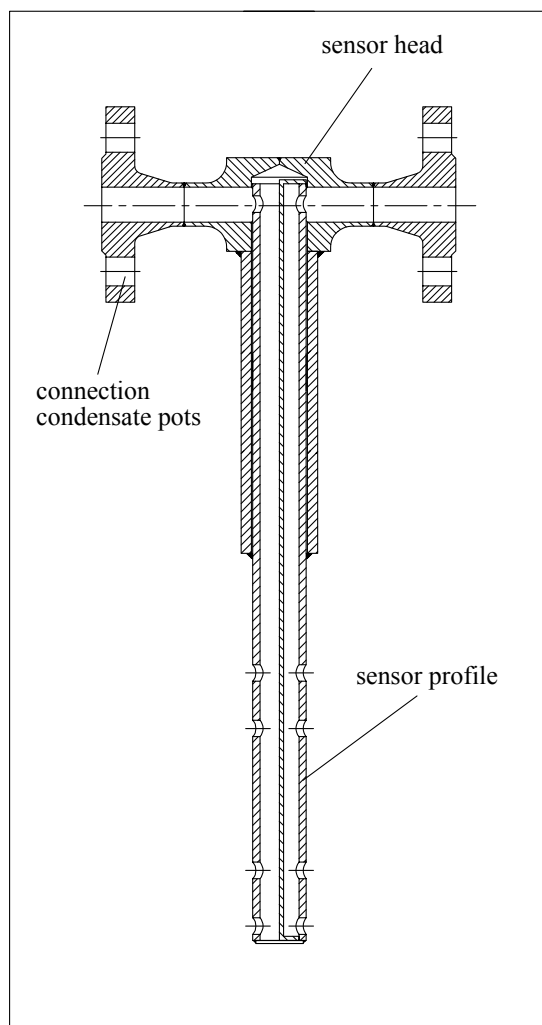

Fig.1: Cross section ITABAR flow sensor

2. General

FTMD Flo-Tap Sensors are designed for installation under pressure in lines with static pressure up to 16bar and to 300°C with graphite packing gland.

All items for installation are provided with Flo-Taps except for drilling and welding equipment.

These instructions call for the use of a Mueller DH-5 drilling machine (or equivalent), which is rated for 80 bar at 35°C with a maximum temperature of 120°C. This machine will handle the installation under pressure of the Flo-Tap Sensor FTMD 25 under its full rated pressure of 70 bar. Other drilling machines are available.

The sensor material and the mounting hardware can be specially selected to accommodate special operating conditions (e.g. corrosive media).

3. Pre-Installation Checks

Before installation, make sure that all of the following parts are included in the sensor kit.

- ITABAR Sensor, type FTMD
- condensate pots flanged
- Weld socket
- gaskets for condensate pots flanged
- Sensor end support, with sealing plug (for FTMD 26 only)
- Instrument valve assembly (if ordered)

Compare the specifications at the type identification plate of the sensor with your order form.

The identification plate contains the following information:

- Serial number
- Type name
- Pipe inside diameter
- TAG number (Measuring location number - if furnished)
- Material

Attention!

Make sure that the pipe inside diameter given on the identification plate matches your pipe diameter.

4. Equipment required for installation

1. Welding equipment
2. Pressure (hot-tap) drilling machine; Mueller type DH-5 or equivalent.
3. 1 1/16" drill bit Mueller 33530
4. Drill holder Mueller 33555
5. Adapter nipple Mueller 36195

(Items 2 through 5 are available from Mueller Co., Decatur, Illinois. In most cases, the public service company in your city is available to do the "hot-tapping" job, or the equipment may be rented or purchased locally.)

Pressure drill machine and tooling:

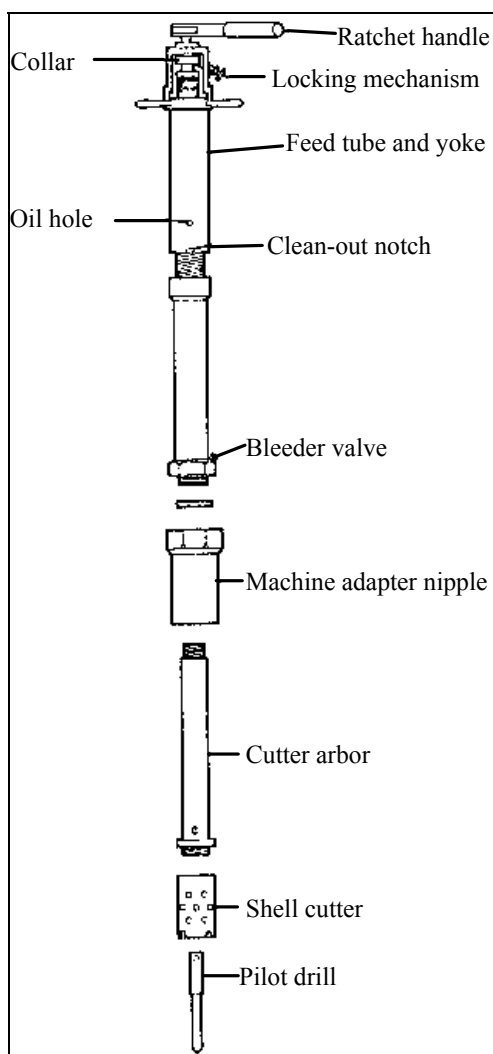

5. General Installation Notes

In order to obtain optimal measurement results, follow the notes concerning the installation of the ITABAR Sensor given below.

5.1 Determination of Pipe Arrangement

For design reasons, the pipe arrangement at the installation location has to be known before the sensor is manufactured.

For horizontal pipe arrangements the instrument connections are placed in-line with the flow direction (see Figure 2).

For vertical pipe arrangements, the instrument connections for the measurement of the differential pressure are arranged at an angle of 90° to the flow direction (see Figure 3).

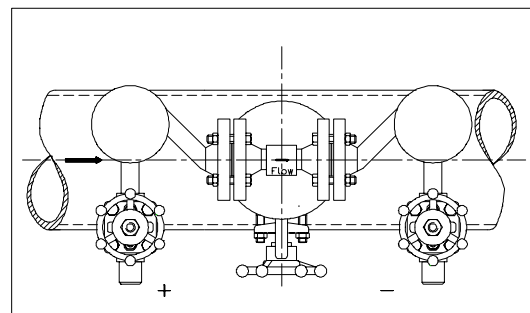

Fig. 2: Placement of the differential pressure connecting studs for horizontal pipe arrangement

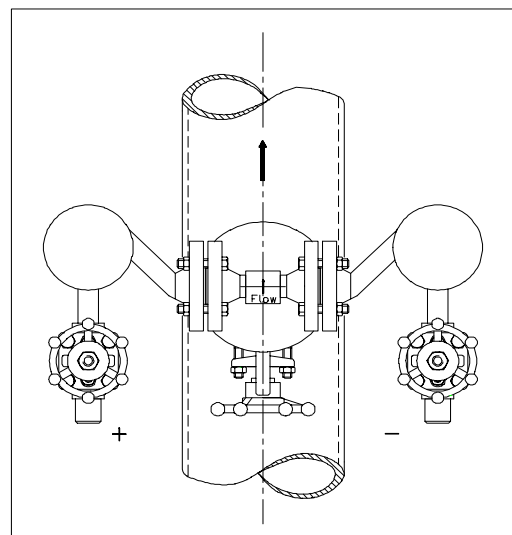

Fig. 3: Placement of the differential pressure connecting studs for vertical pipe arrangement

|| The flow direction is indicated in each case by an arrow on the sensor head. ||

5.2 Vertical Pipe Arrangement

The ITABAR Sensor for flow measurement of steam and saturated steam can be installed in vertical pipe runs at any location, however, the instrument connections have to be located in the same horizontal plain (see Figure 4).

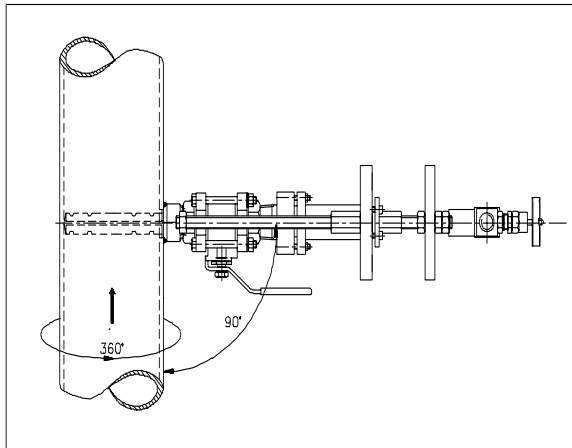

Fig. 4: Installation in vertical pipe

5.3 Horizontal Pipe Arrangement

For flow measurements in a horizontal pipe the ITABAR Sensor must be installed in the lower half of the pipe circumference; the connections to the instruments have to be located below the pipe axis.

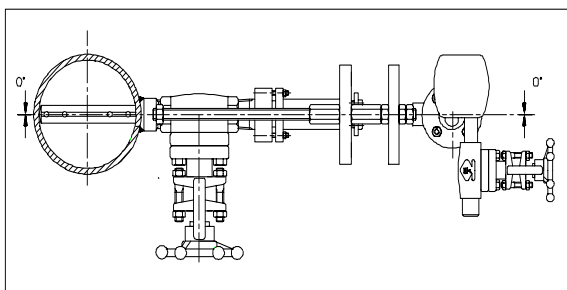

Fig. 5: Installation in horizontal pipe

5.4 Misalignment

The ITABAR Sensor operates on the basis of simple physical principles.

The sensor is not affected by being slightly out of alignment.

The influence on the accuracy of the measurements is negligible as long as the limits indicated in Figures 6, 7 and 8 are not exceeded.

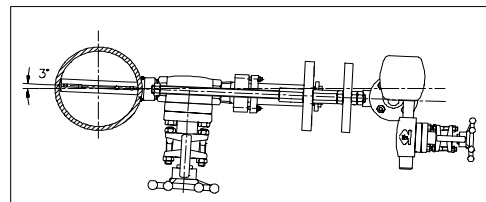

Fig. 6 side view

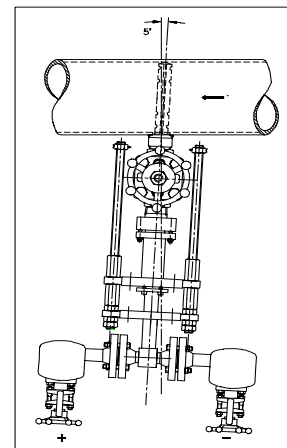

Fig. 7 top view

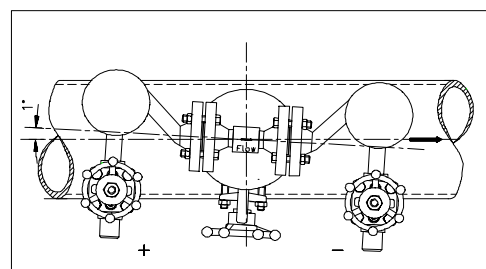

Fig. 8 front view

**5.5 Required Undisturbed Pipe Run Lengths
(in multiples of D)**

The accuracy of the measurements of the ITABAR Sensor depends on the development of a stream profile which should be as undisturbed as possible. Therefore the selection of the installation location within the pipe run is of considerable importance. The following tried and true hints regarding the required pipe lengths ahead of and behind the sensor are designed to help you in your selection of the most advantageous installation location. As a general rule, regulating valves, throttle valves and gate-type valves should be installed behind the sensor.

Note:

If the recommended straight pipe run lengths are not available, the measuring accuracy can be adjusted to the specific conditions of the measuring stretch by conducting a comparison measurement (e.g. Pitot tube, point measurement). The point measurement guarantees that the differential pressure corresponds to the true flow velocity, thereby assuring the specified accuracy. Details can be requested from the manufacturer.

D = Pipe Diameter	A = Upstream	B = Downstream
	7	3
	9	3
	17	4
	18	4
Restriction in the Pipe Run 	7	3
Widening of the Pipe Run 	7	3
Regulation Device 	24	4

6. Installation of the ITABAR Sensor

Observe the general installation notes!

6.1 Installation of Type FTM-20 and FTM-25

1. Verify that the line pressure is within rated limits of the drilling equipment to be used.
2. Grind off paint or other coatings from the pipe in the area where the Flo-Tap is to be installed.
3. Tack the mounting stud {1} (supplied with the Flo-Tap) onto the pipe leaving a clearance of 1-2 mm (Fig. 9).
4. Check the alignment of the mounting stud again. Then the finish weld can be made.
5. Fasten unit isolating valve {2} to the mounting stud {1} and open valve. (Fig. 9).

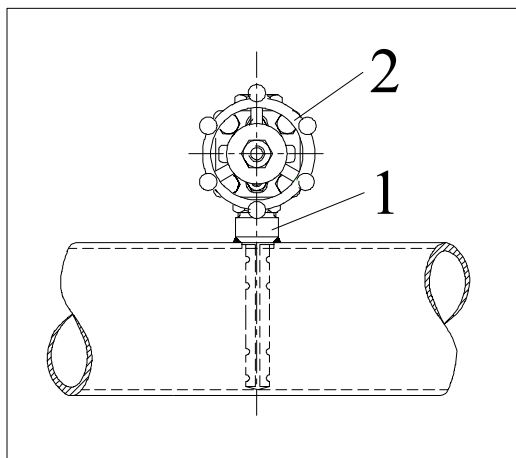

Fig. 9: Mounting stud with isolating valve

6. Fasten special adapter flanged nipple to unit isolating valve (Fig. 10).
7. Install cutter arbor, shell cutter and pilot drill to pressure drilling machine and attach the machine to its special flanged nipple.
8. Drill through the pipe wall in accordance with the instructions supplied with the drilling machine. For type FTMD-25 \varnothing 35mm.
9. Withdraw the drill past the Flo-Tap unit isolating valve. Close the unit valve and remove drilling machine and special flanged nipple. Check for leakage at valve and connections.
10. Verify that the sensor profile {4} is fully retracted in the protection pipe {3}. Check the position of the threaded rod (Fig. 11)

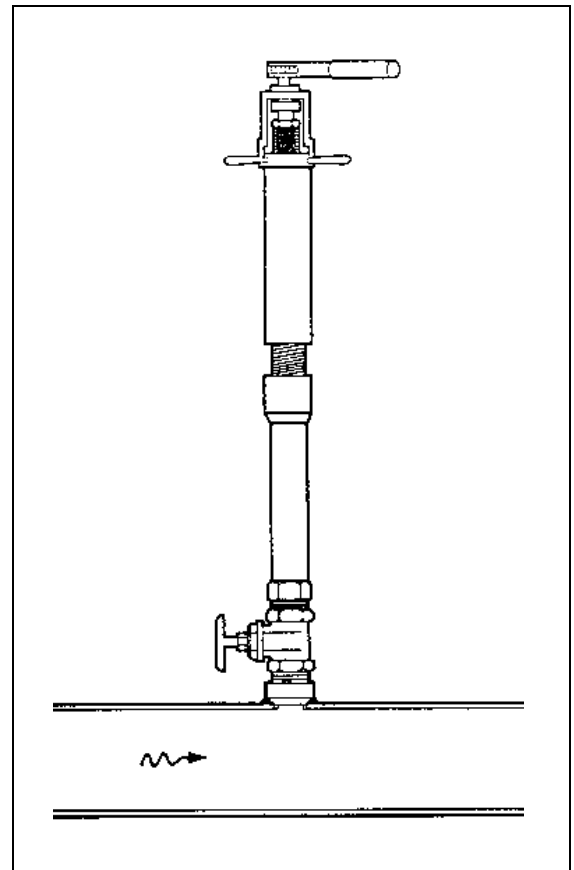

Fig. 10: Drilling machine with adapter nipple mounted on unit isolating valve

11. Now seal the threaded stud {5} with a suitable sealing compound (Fig. 11).
12. Install the threaded stud {5} on the isolating valve {2} (Fig. 9 and 11).
13. Verify that the instrument valves are fully closed.
14. Check all connections for leakage by cracking open the unit isolating valve. If necessary, screw down the 4 screws {6} of the top packing gland and the 4 screw nuts {7} of the bottom packing gland (Fig. 11).
15. Increase line pressure to normal limits and check for leakage. If there is no apparent leakage, proceed to Flo-Tap Insertion 6.3.

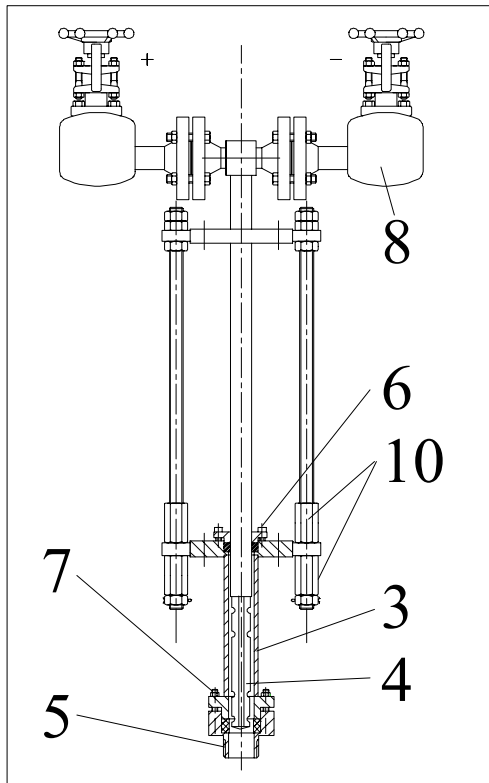

Fig. 11 Sensor profile with protection pipe

6.2 Installation of Type FTMD-26

The design of the ITABAR Sensor of the type FTMD-26 is almost identical to the type FTMD-25. The only difference is the sensor end support (with sealing plug, see Fig. 12) which permits higher stream velocities in the pipe.

Attention!

Due to construction of the FTMD-26 with end support it would cause many problems to install it for the first time during operation.

We recommend you to install this type during operation stop as per following instructions.

After installation also this sensor can be rejected and inserted as type FTMD-25 under pressure.

Installation of weld socket:

1. Drill a hole of 35 mm diameter into the pipe.
2. Tack the weld socket {1} onto the pipe leaving approx. 2 mm clearance. Align the socket (e.g. with a bolt or pin) so that it is exactly perpendicular to the pipe axis (Fig. 12).
3. Before final welding and installing the sensor, you have to mount the end support {5}.

Installation of the end support:

4. Take a cord and tie one end around the installed weld socket {4}. Wrap the other end of the cord around the pipe so that it forms a loop around the pipe. Mark the half-way point of the pipe circumference on the pipe.
5. Now drill a second hole of $\varnothing 35$ mm diameter into the pipe.
6. Remove the sealing plug {9} (if present) from the sensor end support. Tack the sensor end support onto the pipe leaving approximately 2 mm clearance. (Fig. 12)
7. Insert the sensor into the pipe and check the alignment of the sensor end support. If necessary, correct the alignment.

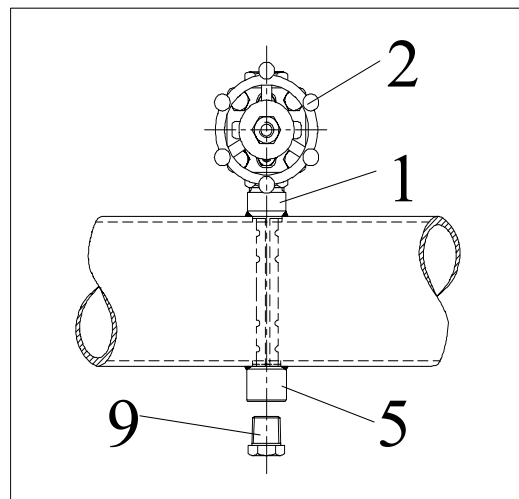

Fig. 12: Installation hardware and sensor end support

8. Now the final welding can be carried out. Check the alignment of the weld socket again! For permissible deviations, see chapter 5.4. .
9. For sensor end supports with sealing plug only: Seal the thread of the sealing plug {9} with a suitable sealing compound (e.g. PTFE tape). Screw the sealing plug into the sensor end support and tighten it firmly (Fig. 12).
10. Install the Flo-Tap unit isolating valve {2} on the welding socket. Verify that the valve is in fully open position, and that the stem is in line with the pipe to insure clearance for the insert-retract rods.
11. Perform the installation of the sensor into the pipe according to the instructions given in chapter 6.1 steps 10 through 15.

6.3 Insertion Procedure for FTMD

1. Verify that the Flo-Tap insert-retract mechanism are in the position as shown in Fig. 13.
2. Verify that the Flo-Tap instrument valves {8} are fully closed and that the unit isolating valve {2} is fully open (Fig. 13 and 14).

3. Initiate probe insertion by rotating the drive nuts {10} clockwise as viewed from the top, using ratchet wrench. The nuts must be tightened alternately, about two turns at a time to prevent binding resulting from unequal loading.

Continue this procedure until probe contacts the opposite side of the pipe or end support (FTMD-26)

4. Inspect the packing gland for evidence of leakage. If the unit was ordered with high-temperature gland, additional adjustment may be required at this time.

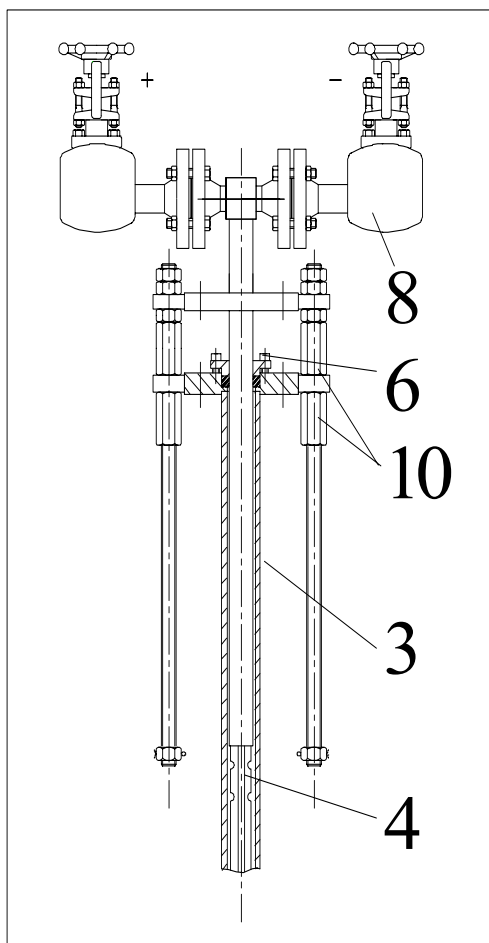

Fig. 13 retracted Flo-Tap Sensor

5. Connect instrument lines to the instrument valves and to the appropriate meter, recorder, transmitter or controller.
6. Open the Flo-Tap instrument valves {8}. Then purge or bleed the connecting lines and readout equipment as required.

6.4 Retract Procedure for FTMD

1. Fully close the Flo-Tap instrument valves {8}. Then, if required, depressurize and disconnect the instrument lines.
2. Loosen slightly packing gland {6+7} before proceeding with retraction.
3. Retract the Flo-Tap by rotating the drive nuts {10} clockwise as viewed from the top, using ratched wrench. The nuts must be turned alternately, about two turns a time, to prevent binding resulting from unequal loading.

Continue this procedure until the probe is fully retracted as shown in Fig. 14.

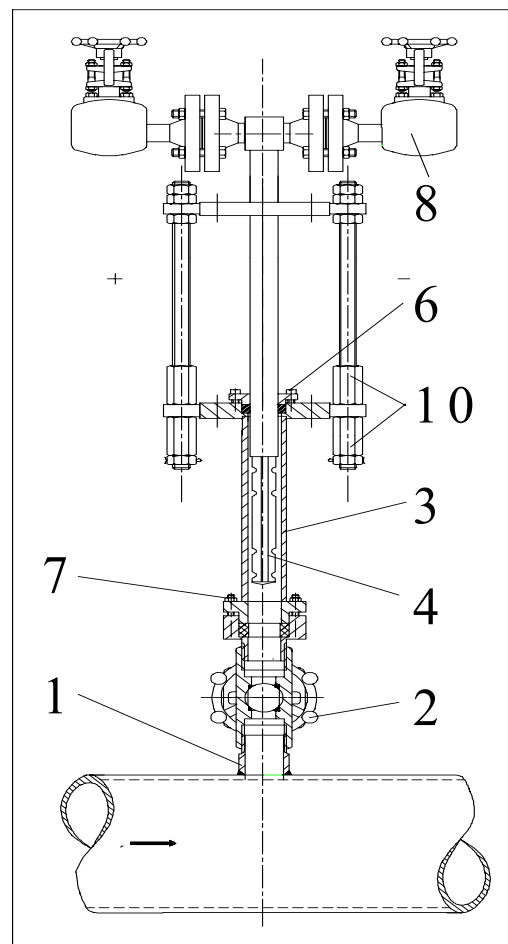

Fig. 14 retracted Flo-Tap Sensor

4. After the probe is fully retracted, the Flo-Tap unit isolating valve {2} may closed for complete disassembly.

7. Insulation

It is important for proper operation of the ITABAR steam sensor that the phase change from vapour to liquid take place only in the therefore specially designed condensation vessels and not in the head of the sensor.

Attention!

Do not insulate the condensation vessels.

The media in the differential pressure lines and transmitter must be in a liquid state.

8. Installation of valve block and Δp -transmitter

8.1. Valve block

For steam measurement a 3-valve instrument manifold is recommended. The valves of a 3-valves manifold have the following functions:

- Valve C and D shut-off to transmitter,
- Valve E Bypass valve (transmitter zero),

If a 5-valve instrument manifold be used the valve has additional function:

- valve F and G for drains

See Fig. 11

8.2. Δp -Transmitter:

For steam measurements, the differential pressure transmitter should always be installed below the ITABAR sensor in order to avoid the occurrence of air bubbles in the instrument connections (see Fig. 11). Take care to mount the dp-transmitter exactly horizontal, otherwise a small difference to alignment is followed by a zero point error.

We recommend you to install the differential pressure lines close together (connect hi and lo line heat conducting) to maintain equal temperature.

Attention!

The differential pressure lines must have a min. inside diameter from 10mm. Because the max. drop diameter from water is 6,5mm.

(Prandl, L. "Führer durch Strömungslehre")

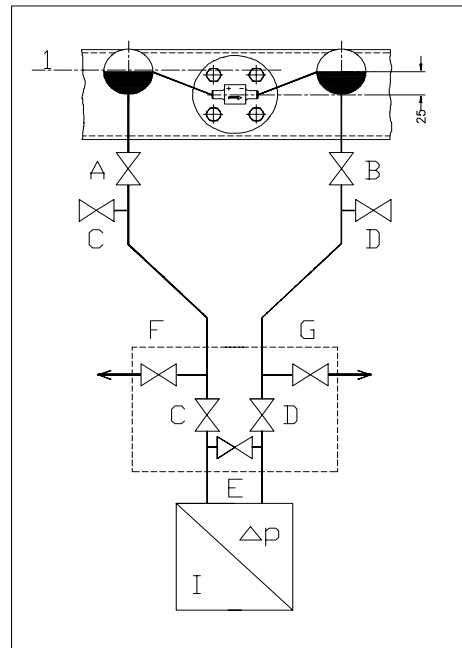

Fig. 11

9. Measurement Start-Up

Make sure that:

- all installation openings are closed,
- all installed parts are securely bolted together,
- all shut-off valves are closed,
- close valve A and B for 15 minutes, so that water can constitute in the condensate pots.
- all valves of 3- or 5-way manifold are closed.
- open valves A and B, after then all valves at the 3-way manifold.

Attention: If a 5-way manifold valve are mounted

valves F and G must be closed, because after the

condensate steam penetrate and this can be dangerous for personal.

- After 5 minutes, water will be constitute from the lowest point to the condensate pots.
- close valves A and B and open vent valves C and D, so air bubbles can escape.
- close valves C and D again, the transmitter must show an 4 mA signal. By using a transmitter with 0-20 mA output, it must be 0 mA.
- If the output signal from the transmitter is more then 0 or 4 mA, the condensate pots don't have the same level.
- By difference, the transmitter must adjust to 0 or 4 mA.
- close valve E of the 3- or 5-way manifold. After open valves A and B, the measuring are in operation.

- If the mA- signal have big bounce, the valves A and B must be closed and the system must be vented again.

10. Preventive Maintenance

ITABAR sensors are intensive to dirt and soil build-up and therefore nearly maintenance-free.

However, if cleaning is required:

- remove the sensor
- flush completely
- hand clean with a soft wire brush

11. Trouble shooting

If, after start-up of the ITABAR sensor, any measuring errors occur, they may possibly be corrected quite easily:

Error:

No differential pressure indication.

Correction:

Check whether all instrument valves to the Δp -transmitter are opened.

The valve E must be closed (only for zero).

Check the alignment of the sensor with the pipe.

The arrow on the sensor must point exactly in the flow direction (downstream).

Note:

Two-Phase flow or alternating phase flow will cause an erratic spiking signal. The ITABAR sensors are head-measuring devices and will not accurately measure two-phase flow.

ITABAR-Flow-Sensors for low pressure steam have condensate pots in which the condensate water line is 25mm higher than the flange connection of the sensor is installed precise horizontal.

That means that water column of static and dynamic pressure side must have the same high to guarantee zero differential pressure when steam is not flowing.

The arrangement of higher condensate line than sensor connection has been done to secure the exact water column onto the d.p. transmitter.

During steam flow the steam will move into the condensate pots and will condensate to water. The water level above line 1 will flow back into the sensor and change again into steam. The steam pressure from dynamic and static connection is pressing onto the water level and the difference at these pressures will be transmitted into mA-signal through the differential pressure transmitter.

Please note that 25mm deviation in the line of 1 will give 25mm WG differential pressure.